The background of the slide is a dark blue-tinted photograph of a large truck driving on a road. The truck is positioned in the center of the frame, moving towards the viewer. The road is flanked by trees and a fence, and the overall scene is dimly lit, creating a professional and focused atmosphere.

HVNL information session: Performance Base Standard (PBS) scheme

Tara McFarlane – PBS VA Manager

ACKNOWLEDGEMENT OF COUNTRY

The National Heavy Vehicle Regulator (NHVR) acknowledges the Traditional Custodians of the lands across the nation. We recognise the deep and lasting connection that Aboriginal and Torres Strait Islander peoples have to the lands and waters across the country and thank Aboriginal and Torres Strait Islander people for caring for the lands for over 60,000 years. We also pay our respects to Elders past and present and to emerging community leaders. We acknowledge that many of Australia's major road networks are attributed to First Nations peoples having used star maps as way points on their journey through Australia's harsh terrain to reach landmarks such as watering holes.



Agenda

1. Session overview
3. NHVAS and HVA requirements
2. GML uplift and design and Vehicle Approvals
4. Euro VI updates
5. Tri-drive and tridem hauling units and the Euro VI mass transfer
6. General Access Length increase

After the HVNL Implementation Date, the below updates will be made:

- Accreditation will not be required for CML (Concession Mass Limits). This condition will no longer appear on VAs issued after 1 August 2026.
- Accreditation will still be required for PBS Combinations in other cases such as split-axle and quad axle combinations and for certain combinations at HML masses. Due to the 3-year transition period, the conditions on VAs issued after 1 August 2026 will state operators with either NHVAS or HVA will be deemed compliant.
- All VAs issued after the 1 August 2026 will have updated conditions.
- VAs can still be used if they contain the words CML after the implementation date – the requirement for accreditation will no longer be enforced.

PBS Scheme – GML Uplift



All previously issued DAs and VAs will still be deemed compliant – updates will not be retroactively applied.

The PBS Team will only update the labels on VAs that require a VA number change after the HVNL Implementation Date.

Previous Format

Mass Limits	Level 1	Axle Group Masses	Level 1		
			GML	CML	HML
GML (t)	50.5	Steer (t)	6.5	6.5	6.5
CML (t)	50.5	Drive (t)	16.5	17.0	17.0
HML (t)	50.5	Trailer Front (t)	16.5	17.0	17.0
Bridge Assessment	Tier 2/3	Trailer Rear (t)	16.5	17.0	17.0

New Format

Mass Limits	Level 1	Axle Group Masses	Level 1		
			GML 1	GML 2	HML
GML 1 (t)	50.5	Steer (t)	6.5	6.5	6.5
GML 2 (t)	50.5	Drive (t)	16.5	17.0	17.0
HML (t)	50.5	Trailer Front (t)	16.5	17.0	17.0
Bridge Assessment	Tier 2/3	Trailer Rear (t)	16.5	17.0	17.0

PBS Scheme - New VAs



All brand-new VAs issued from brand new DAs after the implementation of HVNL will have no references to CML.

Mass Limits	Level 3	Axle Group Masses	Level 3	
			GML	HML
GML (t)	81.5	Steer (t)	6.5	6.5
HML (t)	85.5	Drive (t)	17.0	17.0
Bridge Assessment	Tier 1	Lead Trailer (t)	21.0	22.5
		Dolly (t)	17.0	17.0
		Rear Trailer (t)	21.0	22.5

PBS Scheme - Pavement Vertical Loading

DAs and VAs issued after the HVNL Implementation date will no longer contain the Pavement Vertical Loading Standard Exemption and the associated conditions.



Approval under section 8 of the Heavy Vehicle (General) National Regulation – Non compliance	
A heavy vehicle built to this design does not comply with the following Infrastructure Standard/s:	Pavement Vertical Loading (A1) A Section 8 exemption is given for this standard.
Condition:	Any PBS vehicle approval with a Euro VI vehicle (complying steer axle) Road Train combination and applicable mass transfer will be subject to the condition that the vehicle may only be operated under an agreement made with each responsible road authority and road manager for roads on which the vehicle is to operate.

This exemption can be disregarded on all VAs after the implementation date. We can remove the condition upon request from a PBS certifier without resulting in a VA number change.

PBS Scheme – Tri-drive and Tridem combinations

- From the HVNL implementation date combinations containing a hauling unit with a tri-drive or tridem drive axle group will not be able to access the Euro VI mass transfer concession. The additional 500kg will need to be all on the steer.
- Any VAs will continue to be valid if issued before the implementation date, but we cannot guarantee Road Manager approval with these masses.

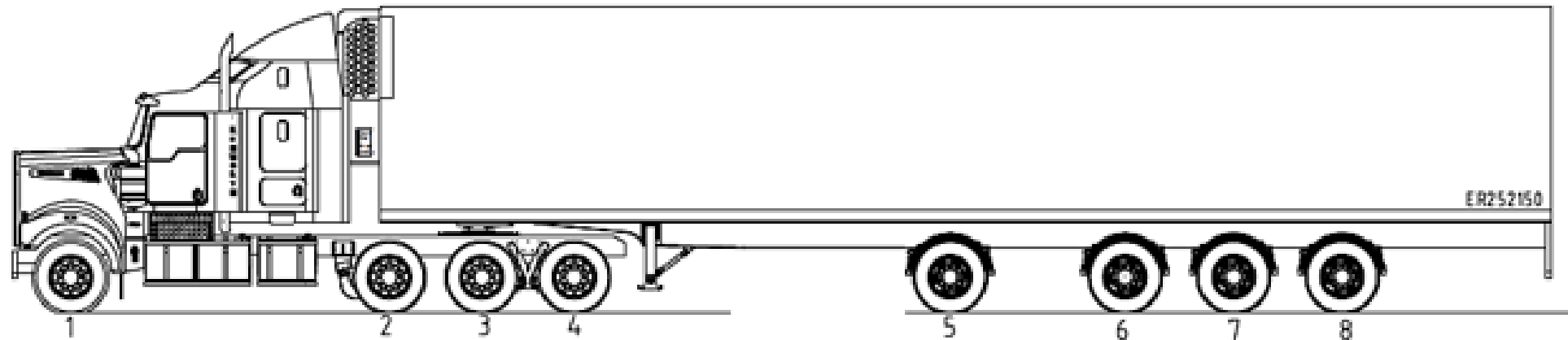

PBS Scheme – General Access Length Increases



Truck and Trailer Combinations:

- Truck and Dog
- Truck and Pig
- Truck and Tag Trailer

Prime-mover and Semi-trailer

No processing changes to Design Approvals or Vehicle Approvals
– Current exemptions will still be in place.

No additional exemptions are able to be provided above the exemptions already available in the PBS Scheme. If a combination is over 20m, a permit will be required for level 1 access.

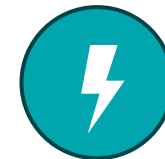

Questions and Next steps



- Please use the Q&A button to ask a question
- If you see a question that resonates and you'd like to hear more, please 'up vote it'

Good To Know

- Changes will automatically apply from the HVNL Implementation date even if submitted before this date
- Please speak with your PBS Assessor or Certifier if you have any specific concerns about your DA or VA

For More Information

- Review our website [NHVR.gov.au](https://www.nhvr.gov.au), and [HVNL updates for the PBS Scheme](#).
- Subscribe to the NHVR's [On the Road newsletter](#) for updates and information
- NHVR Contact Centre by email: info@nhvr.gov.au / phone: 13 NHVR (13 64 87)

Thank you

For more information:

13 NHVR (13 64 87)

info@nhvr.gov.au

nhvr.gov.au

 nhvrsocial

 nhvrsocial

 NHVR

 National Heavy Vehicle Regulator